

Ref.: 508252



## HEAVY DUTY LARGE CAPACITY HOSE REEL, RM-100 SERIES, 30 M, 1/2", AIR / WATER / COOLANT / DIESEL / LUBRICANT OIL / WASTE OIL

Very tough construction large capacity reels, able to stand regular use and abuse in Intensive Duty applications. Fatigue resistant steel spring for years of durable performance and even load when pulling and recoiling the hose. Full port shaft and swivel for no restrictions. Spool mounted on two permanent lubricated and sealed ball bearings to reduce torque load on spring for smooth retraction and longer life. Large effective radial latching area for easier operation. Hose guide arm can be placed in different positions to accommodate any method of mounting. Narrow footprint allows accommodating more reels on the same surface. Reels with longer hose capacity include a dual spring for effective hose retraction. Hose reels with hose include 0,8 m inlet hose. Model with 30 m 1/2" hose for AIR / WATER / COOLANT / DIESEL / LUBRICANT OIL / WASTE OIL. Instruction book: 850821.

### Technical data

### Documentation

### More information

<b>Compatible fluids</b>	Air, Water, Coolant, Oil, Waste oil, Diesel
<b>Hose in diameter</b>	1/2"
<b>Hose length</b>	30 m (98,43 ft)
<b>Fluid Inlet</b>	1" BSP (M)
<b>Fluid outlet</b>	1/2" BSP (M)
<b>Working Pressure</b>	90 bar (1300 psi)
<b>Installation options</b>	Floor, Tank
<b>Bare reel part number</b>	508942
<b>Weight</b>	55 kg (121,3 lb)

### Technical data

### Documentation

### More information

## Instruction manuals

850821 Instruction book: Heavy duty large capacity hose reel, RM-100 series (PDF)

[Download](#)

## Catalogs

Product catalogue: REELS, 2023 EN (PDF)

[Download](#)

## Spare parts

**Technical data**

**Documentation**

**More information**

mm (inches)		508 942	508 944
PART No.	508 925	508 942	508 944
A	315 (12 3/8")	349 (13 3/4")	
B	290 (11 3/8")	320 (12 5/16")	
C	320 (12 5/16")	353 (13 15/16")	

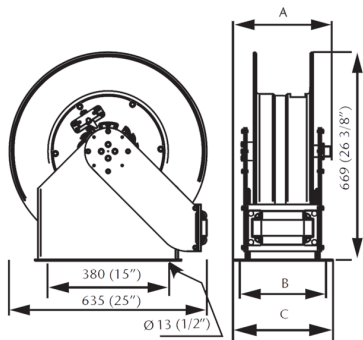

**Models**

Code	Compatible Fluids	Hose In Diameter	Hose Length	Working Pressure
508252	Air, Water, Coolant, Oil, Waste oil, Diesel	1/2"	30 m (98,43 ft)	90 bar (1300 psi)
508244	Air, Water, Coolant, Oil, Waste oil, Diesel	3/4"	25 m (82,02 ft)	90 bar (1300 psi)
508234	Air, Water, Coolant, Oil, Waste oil, Diesel	3/4"	20 m (65,62 ft)	90 bar (1300 psi)
508225	Air, Water, Coolant, Oil, Waste oil, Diesel	1"	15 m (49,21 ft)	90 bar (1300 psi)