

Ref.: 537630



## PNEUMATIC PISTON OIL PUMP, PUMPMaster 60, PM60 - 6:1, STUB

PM60 series air operated piston pumps. Double acting air operated medium pressure and high delivery pump, for large installations with simultaneous operation outlets and applications that require large, constant delivery rates. Built in port for optional pressure relief valve (PN 609 007). Flange mounted pump. Maximum air consumption with 5 bar (72 psi) air inlet pressure and 60 cpm. Maximum noise level measured at 1 m (3.3') from the pump, 7 bar (102 psi) air pressure and free delivery. Instruction book: 853809.

### Technical data

### Documentation

### More information

<b>Fluids</b>	Oil
<b>Compatible fluids</b>	Oil, Transmission fluid
<b>Pump mounting</b>	Universal stub pump
<b>Pressure ratio</b>	6:1
<b>Air pressure operating range</b>	1,5-12 bar (21,75-174 psi)
<b>Air consumption</b>	1100 NL/min (39 scfm)
<b>Maximum outlet pressure</b>	72 bar (1044 psi)
<b>Air motor effective diameter</b>	150 mm (6")
<b>Air motor stroke</b>	100 mm (4")
<b>Delivery per cycle</b>	35 l (9,25 gal)
<b>Cycles per minute (aprox.)</b>	60 cycles
<b>Delivery</b>	35 l/min (9,2 gal/min)
<b>Maximum free flow delivery</b>	100 l/min (26,4 gal/min)
<b>Air inlet</b>	1/2" BSP (F)
<b>Fluid inlet</b>	1 1/2" BSP (F)
<b>Fluid inlet type</b>	Ball check
<b>Fluid outlet</b>	3/4" BSP (F)
<b>Wetted materials</b>	Cast iron, Aluminium, Nickel, Steel, Polyurethane, NBR
<b>Pump tube material</b>	Carbon steel
<b>Sound level</b>	80 dB
<b>Tube height</b>	200 mm (7,9")
<b>Total height</b>	716 mm (28,2")
<b>Weight</b>	19 kg (42 lb)

### Technical data

### Documentation

### More information

## Instruction manuals

853809 Instruction book: Pneumatic piston oil pump, Pumpmaster 60, PM60 - 6:1 (PDF)

[Download](#)

## Catalogs

Product catalogue: GENERAL EXPORT, 2024 EN (PDF)

[Download](#)

## Spare parts

Spare part document: PM6005 537630 (PDF)

[Download](#)

### Technical data

### Documentation

### More information

mm (in)	537 630
A	721 (28 25/64")
B	461 (18 5/32")
C	204 (8 1/32")
D	1 1/2" BSP - F

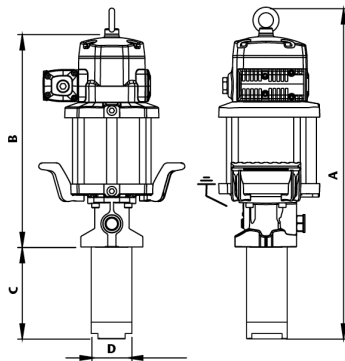

PM60, RATIO 6:1 SAE 10, 21 °C (70 °F)

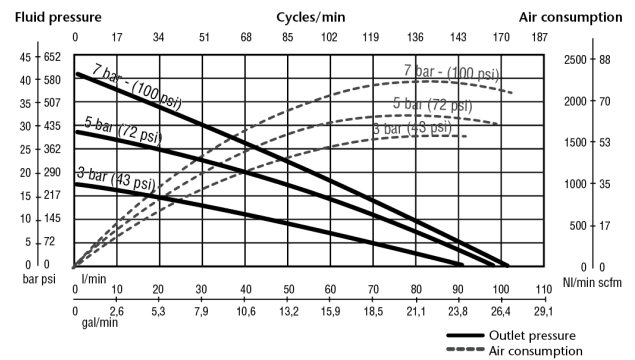

## Models

Code	Fluids	Pump Mounting	Fluid Outlet	Tube Height	Total Height
537630	Oil	Universal stub pump	3/4" BSP (F)	200 mm (7,9")	716 mm (28,2")
537631	Oil	Universal stub pump	3/4" NPT (F)	200 mm (7,9")	716 mm (28,2")