

Ref.: 537130



PNEUMATIC PISTON OIL PUMP, PUMPMaster 60, PM60 - 12:1, STUB

PM60 series air operated piston pumps. Double acting air operated moderate pressure and high delivery for very large installation with simultaneous operation outlets or when low air pressure would limit pump performances. Built in port for optional pressure relief valve (PN 609 007). Flange mounted pump. Maximum air consumption with 5 bar (72 psi) air inlet pressure and 60 cpm. Maximum noise level measured at 1 m (3.3') from the pump, 7 bar (102 psi) air pressure and free delivery. Instruction book: 853805.

Technical data

Documentation

More information

Fluids	Oil
Compatible fluids	Oil, Transmission fluid
Pump mounting	Universal stub pump
Pressure ratio	12:1
Air pressure operating range	1,5-12 bar (21,75-174 psi)
Air consumption	1150 NL/min (41 scfm)
Maximum outlet pressure	144 bar (2040 psi)
Air motor effective diameter	150 mm (6")
Air motor stroke	100 mm (4")
Delivery per cycle	20 l (5,3 gal)
Cycles per minute (aprox.)	60 cycles
Delivery	20 l/min (5,3 gal/min)
Maximum free flow delivery	65 l/min (17,2 gal/min)
Air inlet	1/2" BSP (F)
Fluid inlet	1 1/2" BSP (F)
Fluid inlet type	Ball check
Fluid outlet	3/4" BSP (F)
Wetted materials	Cast iron, Hard chromed steel, Steel, Polyurethane, NBR
Pump tube material	Carbon steel
Sound level	80 dB
Tube height	200 mm (7,9")
Total height	716 mm (28,2")
Weight	19 kg (42 lb)

Technical data

Documentation

More information

Instruction manuals

853805 Instruction book: Pneumatic piston oil pump, Pumpmaster 60, PM60 - 12:1 (PDF)

[Download](#)

Catalogs

Product catalogue: GENERAL EXPORT, 2024 EN (PDF)

[Download](#)

Spare parts

Spare part document: PM6004 537130 (PDF)

[Download](#)

Technical data

Documentation

More information

mm (in)	537 130
A	716 (28 1/4")
B	516 (20 1/4")
C	70 (2 3/4")
D	200 (8")

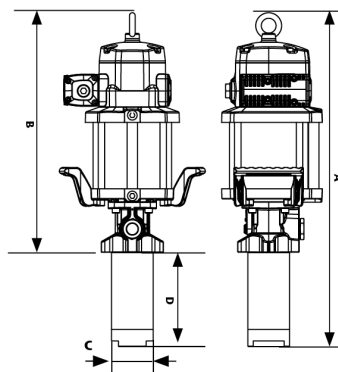

SAE 10, 21 °C (70 °F) CAPACITY CURVE

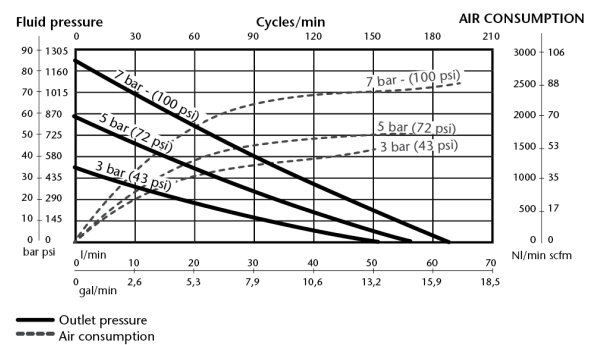

Models

Code	Fluids	Pump Mounting	Fluid Outlet	Tube Height	Total Height
537130	Oil	Universal stub pump	3/4" BSP (F)	200 mm (7,9")	716 mm (28,2")
537131	Oil	Universal stub pump	3/4" NPT (F)	200 mm (7,9")	716 mm (28,2")