

Ref.: 535830



PNEUMATIC PISTON OIL PUMP, PUMPMASTER 35, PM35 - 8:1, STUB WITH ADAPTOR

PM35 series air operated piston pumps. Double acting air operated high pressure pump for oil distribution applications. Pumps include height adjustable 2" BSP (M) bung adaptor for drum and tank bung mounting. Built in port for optional pressure relief valve (PN 609 008). Maximum air consumption with 72 bar (5 psi) air inlet pressure and 80 cpm. Maximum noise level measured at 1 m (3.3') from the pump, 7 bar (100 psi) air pressure and free delivery. Instruction book: 853825.

Technical data

Documentation

More information

Fluids	Oil
Compatible fluids	Oil, Transmission fluid, Corrosion protection fluids
Pump mounting	Universal stub pump with bung adaptor
Pressure ratio	8:1
Air pressure operating range	2-12 bar (29-174 psi)
Air consumption	350 NL/min (12,4 scfm)
Maximum outlet pressure	96 bar (1392 psi)
Air motor effective diameter	80 mm (3,15")
Air motor stroke	80 mm (3,2")
Delivery per cycle	7 l (1,9 gal)
Cycles per minute (aprox.)	80 cycles
Delivery	7 l/min (1,9 gal/min)
Maximum free flow delivery	17 l/min (4,5 gal/min)
Air inlet	3/8" BSP (F)
Fluid inlet	1" BSP (F)
Fluid inlet type	Ball check
Fluid outlet	1/2" BSP (F)
Wetted materials	Cast iron, Hard chromed steel, Steel, Polyurethane, NBR
Pump tube material	Carbon steel
Sound level	80 dB
Tube height	200 mm (7,9")
Total height	487 mm (19")
Weight	6,8 kg (15 lb)

Instruction manuals

853825 Instruction book: Pneumatic piston oil pump, Pumpmaster 35, PM35 - 8:1 (PDF)

[Download](#)

Catalogs

Product catalogue: GENERAL EXPORT, 2024 EN (PDF)

[Download](#)

Spare parts

Spare part document: PM3503 535810 (PDF)

[Download](#)

Technical data

Documentation

More information

mm (in)	535 830
A	487 (19 1/4")
B	287 (11 1/4")
C	42 (1 2/3")
D	200 (8")

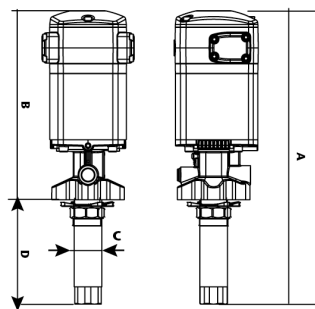

SAE 10, 21 °C (70 °F) CAPACITY CURVE

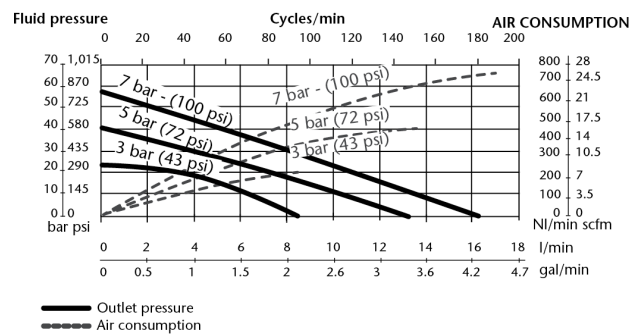

Models

Code	Fluids	Pump Mounting	Fluid Outlet	Tube Height	Total Height
535830	Oil	Universal stub pump with bung adaptor	1/2" BSP (F)	200 mm (7,9")	487 mm (19")
535810	Oil	205 l (55 gal) drum bung mounted	1/2" BSP (F)	925 mm (36,4")	1212 mm (47,7")
535881	Oil	Universal stub pump	1/2" NPT (F)	200 mm (7,9")	487 mm (19")
535880	Oil	Universal stub pump	1/2" BSP (F)	200 mm (7,9")	487 mm (19")
535831	Oil	Universal stub pump with bung adaptor	1/2" NPT (F)	200 mm (7,9")	487 mm (19")
535811	Oil	205 l (55 gal) drum bung mounted	1/2" NPT (F)	925 mm (36,4")	1212 mm (47,7")