

Ref.: 536330



PNEUMATIC PISTON OIL PUMP, PUMPMaster 45, PM45 - 3:1, STUB

PM45 series air operated piston pumps. Double acting air operated medium pressure and high delivery pump for large volume transfer applications. Built in port for optional pressure relief valve (PN 609 007). Flange mounted pump. Maximum air consumption with 5 bar (72 psi) air inlet pressure and 80 cpm. Maximum noise level measured at 1 m (3.3') from the pump, 7 bar (102 psi) air pressure and free delivery. Instruction book: 853803.

Technical data

Documentation

More information

| | |
|-------------------------------------|--|
| Fluids | Oil |
| Compatible fluids | Oil, Transmission fluid |
| Pump mounting | Universal stub pump |
| Pressure ratio | 3:1 |
| Air pressure operating range | 1,5-12 bar (21,75-174 psi) |
| Air consumption | 800 NL/min (28 scfm) |
| Maximum outlet pressure | 36 bar (522 psi) |
| Air motor effective diameter | 115 mm (4,5") |
| Air motor stroke | 100 mm (4") |
| Delivery per cycle | 45 l (11,88 gal) |
| Cycles per minute (aprox.) | 80 cycles |
| Delivery | 45 l/min (11,8 gal/min) |
| Maximum free flow delivery | 120 l/min (31,7 gal/min) |
| Air inlet | 1/2" BSP (F) |
| Fluid inlet | 1 1/2" BSP (F) |
| Fluid inlet type | Ball check |
| Fluid outlet | 3/4" BSP (F) |
| Wetted materials | Cast iron, Nickel, Aluminium, Steel, Polyurethane, NBR |
| Pump tube material | Carbon steel |
| Sound level | 80 dB |
| Tube height | 200 mm (7,9") |
| Total height | 702 mm (2,3") |
| Weight | 17 kg (37,5 lb) |

Technical data

Documentation

More information

Instruction manuals

853803 Instruction book: Pneumatic piston oil pump, Pumpmaster 45, PM45 - 3:1 (PDF)

[Download](#)

Catalogs

Product catalogue: GENERAL EXPORT, 2024 EN (PDF)

[Download](#)

Spare parts

Spare part document: PM4505 536330 (PDF)

[Download](#)

Technical data

Documentation

More information

| mm (in) | 536 330 |
|---------|-------------|
| A | 702 (28") |
| B | 502 (20") |
| C | 90 (3 1/2") |
| D | 200 (8") |

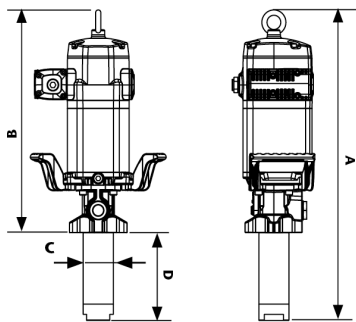

SAE 10, 21 °C (70 °F) CAPACITY CURVE

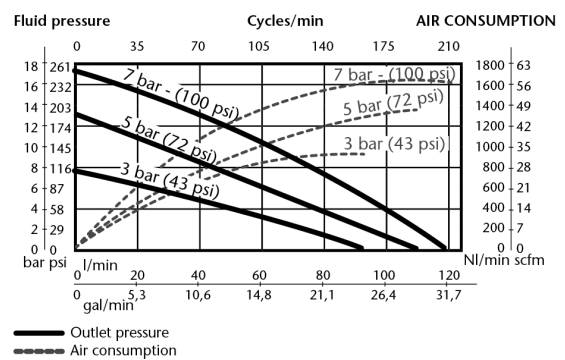

Models

| Code | Fluids | Pump Mounting | Fluid Outlet | Tube Height | Total Height |
|--------|--------|---------------------|--------------|---------------|---------------|
| 536330 | Oil | Universal stub pump | 3/4" BSP (F) | 200 mm (7,9") | 702 mm (2,3") |
| 536331 | Oil | Universal stub pump | 3/4" NPT (F) | 200 mm (7,9") | 702 mm (2,3") |