

Ref.: 501200



DOUBLE PEDESTAL DOUBLE ARM HOSE REEL, RM-12 SERIES, 10 M, 1/2", LUBRICANT OIL

Full metal hose reels, can handle up to 10 m x 1/2" hose. Fatigue resistant steel spring for years of durable performance and even load when pulling and recoiling the hose. Full metal double pedestal arm construction, epoxy powder coated for increased wear resistance. Forged brass shaft ensures a leak free operation. Hose reels with hose include 0,8 m inlet hose. Model with 10 m 1/2" hose for LUBRICANT OIL. Instruction books: 850801 and 836823.

Technical data

Documentation

More information

Compatible fluids	Oil
Hose in diameter	1/2"
Hose length	10 m (32,81 ft)
Fluid Inlet	1/2" BSP (M)
Fluid outlet	1/2" BSP (M)
Working Pressure	160 bar (2320 psi)
Installation options	Floor, Wall, Ceiling, Tank
Bare reel part number	501298
Weight	20 kg (44 lb)

Technical data

Documentation

More information

Instruction manuals

836823 Instruction book: Template for hose reel installation (PDF)

[Download](#)

850801 Instruction book: Double pedestal double arm hose reel, RM-12 series (PDF)

[Download](#)

Catalogs

Product catalogue: REELS, 2023 EN (PDF)

[Download](#)

Spare parts

Spare part document: RM1201 501100 (PDF)

[Download](#)

mm (in)	
A	525 (20 3/4")
B	480 (19")
C	220 (8 5/8")
D	Ø10 (3/8")
E	130 (5 1/8")
F	160 (6 5/16")

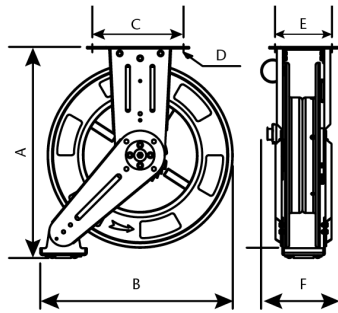

Models

Code	Compatible Fluids	Hose In Diameter	Hose Length	Working Pressure
501200	Oil	1/2"	10 m (32,81 ft)	160 bar (2320 psi)
501300	Grease	1/4"	10 m (32,81 ft)	350 bar (5075 psi)
501100	Air, Water, Coolant	3/8"	10 m (32,81 ft)	15 bar (220 psi)